

# **RADON FLUX MONITOR FOR *IN SITU* MEASUREMENT OF GRANITE AND CONCRETE SURFACES**

Payasada (Paul) Kotrappa<sup>1</sup> and Fredrick Stieff<sup>1</sup>  
Rad Elec Inc.  
5716-A Industry Lane Frederick, MD 21704

Daniel J. Steck<sup>2</sup>  
Physics Department, St. John's University  
Collegeville, MN 56321

## **ABSTRACT**

Recent interest in radon (<sup>222</sup>Rn) emanation from building materials like granite and concrete has sparked the development of a measurement device that is suitable for field or home measurements. Based on test with discrete component flux monitors, a large volume (960 ml) hemispherical electret ion chamber (EIC) was modified to integrate the accumulator and detector, into a single device. The device entrance is covered by a Tyvek sheet to allow radon from granite surface to diffuse into the monitor and further into the upper EIC chamber. The diffusional entrance of radon into EIC is through small area filters. This process reduces thoron sensitivity of EIC. This device is calibrated with a NIST radon emanation standard whose radon emanation rate is precisely known. Side-by-side measurements with other emanation techniques on various granite surfaces in lab and field environments produce comparable emanation results. For low emitting building materials like concrete, a flux of 110 Bq m<sup>-2</sup> d<sup>-1</sup> (11 pCi ft<sup>-2</sup> h<sup>-1</sup>) can be measured with 10% precision using short term electret in 8 hours. Sensitivities, ranges and applicable errors are discussed.

## **INTRODUCTION**

There has been an increased interest in the radon emanation from granite used for countertops and tiles in homes. Radon originates from naturally occurring uranium present in granites and other building materials made from stone. The radon emanation rate of granite, along with the home's volume and ventilation rate determines its contribution to room radon. Radon emanation rate is also called the radon flux and is defined as radon activity released per unit area per unit time. (While the appropriate scientific flux unit would be Bq m<sup>-2</sup> s<sup>-1</sup>, units like Bq m<sup>-2</sup> d<sup>-1</sup> and pCi ft<sup>-2</sup> h<sup>-1</sup> are easier to use in practice. Results are provided in these units with some conversion factors for other units in the text.)

---

<sup>1</sup> These authors are the developers of, and have a commercial interest in, the radon flux monitor described in this paper.

<sup>2</sup> This author does not have a commercial interest in the devices described in this paper.

There are few detailed published studies of granites marketed in the US, but recent reports suggest that most granites have low fluxes with most granites showing a radon flux below  $250 \text{ Bq m}^{-2} \text{ d}^{-1}$  ( $26 \text{ pCi ft}^{-2} \text{ h}^{-1}$ ) with few as high as  $3000 \text{ Bq m}^{-2} \text{ d}^{-1}$  ( $320 \text{ pCi ft}^{-2} \text{ h}^{-1}$ ) (Kitto, 2009). Radon flux can be used in models to estimate the contribution of building materials to indoor airborne radon concentrations under various exposure scenarios. Low indoor radon concentrations ( $<0.4 \text{ pCi/L}$ ) are predicted by the models. However for small living spaces with low ventilation and large installations of tile or countertops much higher radon emanation is predicted. (Steck, 2009)

Radon flux measurements can be difficult in the field because large emanation variations occur in some material surfaces and it is often difficult to sample large areas of material. The best radon generating potential of a material would come from a complete enclosure-type accumulator (Kotrappa, 2009). Since that is usually impractical and measuring samples in the laboratory often mischaracterizes the true average emanation, the goal of this work was to develop a practical, light weight, simple radon flux measuring device that could quickly make measurements at multiple locations on the suspected building materials. After experiments with discrete flux monitors using separate components for the accumulator and radon detector, a new radon flux monitor, was developed, calibrated, and field tested.

## **MATERIALS AND METHODS**

### **RADON FLUX MONITOR (RFM)**

In this paper the integrated radon flux monitor is referred to as RFM. A schematic of the RFM is shown in Figure 1. Radon emanating from the granite surface diffuses through the buffer volume and through four filtered holes (one quarter inch diameter) into an electret ion chamber portion of the flux monitor. The electret ion chamber (EIC) measures radon concentration accumulated during the measured period and is related to radon flux. Most building materials generate both radon ( $^{222}\text{Rn}$ ) and thoron ( $^{220}\text{Rn}$ ) gases. But the difference in decays of these two gases makes the dose generated indoors by thoron a small fraction of the dose generated by radon. However, most field-grade “radon” detectors will respond to thoron at about rate as radon unless steps are taken to limit the thoron that gets into the active volume. This monitor has a unique feature that minimizes the response to thoron. Thoron emanating from granite surface while diffusing through the buffer volume and through four filtered holes effectively decays because of short half life of thoron. The use of small area filtered openings to minimize the response of electret ion chamber for thoron, is a standard method, used in all E-PERM®, EIC radon monitors (Kotrappa, 1990). This RFM has an accumulation volume of 960 ml and a Tyvek-covered window area of  $189 \text{ cm}^2$ .

This monitor uses a well known “accumulation theory” of determining the radon flux from the objects (Kotrappa, 2009). The entire volume of the chamber serves as an accumulator and the electret ion chamber (EIC) part serves as a radon monitor. Equation (1) relates the average radon measured by the EIC and the radon flux  $F$  when the accumulator has no radon losses other than radioactive decay.

$$C(Rn)Av = \frac{(F \times A)}{V \times 0.1814} \left[ 1 - \left( \frac{1 - e^{-0.1814T}}{0.1814T} \right) \right] \text{----- (1)}$$

*Notation:*

*F* is the radon flux in Bq m<sup>-2</sup> d<sup>-1</sup>

*A* is the area of the granite measured in m<sup>2</sup>

*A* is also the area of the radon flux monitor window in m<sup>2</sup>

*(F × A)* is the exhalation rate in Bq d<sup>-1</sup>

*0.1814* is the decay constant of radon in d<sup>-1</sup>

*C(Rn) Av* measured by EIC, is the integrated average radon concentration in Bq m<sup>-3</sup>

*T* is the accumulation time in days

*V* is the air volume of the accumulator in m<sup>3</sup>

The radon flux *F* is calculated using equation (1) leads to a flux in units of Bq m<sup>-2</sup> d<sup>-1</sup>.

Flux in other units can be obtained by multiplying the result by; 0.0116 to convert to mBq m<sup>-2</sup> s<sup>-1</sup>, 0.105 to convert to pCi ft<sup>-2</sup> h<sup>-1</sup>, and 1.125 to convert to pCi m<sup>-2</sup> h<sup>-1</sup>.

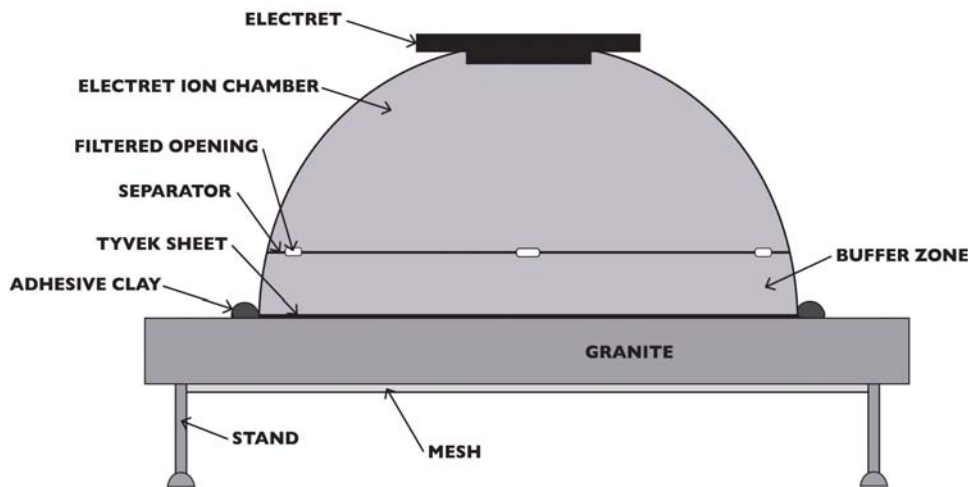

**RADON FLUX MONITOR (SCHEMATIC)**

Fig 1a Schematic details of Radon Flux Monitor

Figure 1a illustrates that the radon flux monitor and Fig 1b illustrates the deployment of radon flux monitor. Radon flux monitor should be positioned on a granite sample which is allowed to emanate freely from both surfaces. It is important to make a good seal with the surface using adhesive clay because the analysis equation assumes that there are no leakage losses from the surface around or through the RFM. A premeasured electret is screwed tight into the radon flux monitor. The edge of this electret should also be sealed with adhesive clay. At the end of desired period (typically 8 hours) the electret is screwed out and measured. The method of calculating radon concentration is similar to that for any EIC.



Fig 1b Deployment of the Radon Flux Monitor

Calibration factors are obtained for this EIC using standard procedures (Kotrappa, 1990). Average radon concentration in the accumulator is calculated using equation (2)

$$\text{Rn concentration} = (I-F) / (CF \times T) \text{ ---- (2)}$$

$$\text{Where } CF = 4.4757 + 0.002634 [(I+F)/2]$$

T is the accumulation time in day units

Rn is the radon concentration in pCi/L

I and F are the initial and final voltages of ST electret

Multiply the measured radon concentration by 37 to convert the radon concentration to units of Bq m<sup>-3</sup> before using it in equation (1).

### **BACKGROUND CORRECTIONS FOR RFM**

Electret ion chambers respond to gamma radiation as well as radon. Therefore, both the ambient gamma radiation and room radon can affect the RFM result. These effects will be most important for low emanation materials and in high radon rooms. To correct for those effects, use a background measuring RFM. The background measuring radon flux monitor is identical to the standard RFM, but the window is covered with 1.5 mm thick PVC disk. This stops the radon from the surface, but not the gamma radiation or the

ambient radon in the room. The background RFM is positioned on the granite, and the background equivalent radon flux calculated by the same procedure. This background flux is subtracted from the measured radon flux to calculate the net radon flux. We have observed that the signal from gamma radiation is very small (2 to 5%) compared to the signal from radon. Background corrections are needed when very accurate measurements are needed.

**CALIBRATING THE RFM WITH NIST RADON EMANATION STANDARDS**

Radon emanation standards (SRM 4971 to 4974) are available from NIST (National Institute of Standards and Technology). Characteristics of radon emanation standards are provided in terms of <sup>226</sup>Ra strength and emanation fraction (Volkovitsky, 2006). The following equation is used to calculate the emanation rate from the characteristics of the standard provided by NIST. Radon emanation rate, R (<sup>222</sup>Rn) is calculated using equation (3) (Kotrappa, 2006).

$$R (^{222}\text{Rn}) = f \cdot A (^{226}\text{Ra}) \cdot \lambda \quad \text{-----} \quad (3)$$

Where,

*f* is the emanation fraction

*A* (<sup>226</sup>Ra) is the radium content in Bq

*λ* is the decay constant of radon in day<sup>-1</sup>

The primary standard used in this work has NIST certified characteristics as: *A* is 5604 Bq, *f* is 0.844, *λ* is 0.1814 day<sup>-1</sup>. The emanation rate is calculated using Equation (3) to be 858 Bq/day with a precision of better than 2 %. (Kotrappa et al 2005).

To calibrate the RFM, peel back the Tyvek and use a little adhesive clay to attach the source to the chamber separator. Seal the edges of RFM to the plastic disk with adhesive clay. Screw in a premeasured long term electret (LT) into the RFM. Put a seal of clay around the screw parts of electret to ensure leak tightness. After 8 hours, unscrew the electret and take a final reading. Follow the standard procedure to calculate the radon emanation rate. Compare this with the theoretically calculated radon emanation rate. The ratio between the expected to the calculated is the correction factor that should be used for multiplying the measured emanation rate for an 8 hour measurement. Table-1 gives the results of the calibration experiments of author PK.

Table-1 Results of Calibration of radon Flux Monitor with a NIST Source  
Expected Emanation Rate: 856 Bq day<sup>-1</sup>

Measurement Number	Accumulation Time hours	Radon Concentration Bq m <sup>-3</sup>	Measured Emanation Rate Bq day <sup>-1</sup>	Av. Ratio of calculated to measured
1	7.83	127,473	764.7	<b>1.104</b>
2	8.0	133,617	785.2	
3	8.0	132,263	777.2	

An independent calibration by author DJS using a different NIST source (4974-8) whose emanation was  $752 \text{ Bq d}^{-1}$  had a Calculated to Measured ratio of 1.20. The RFM with short-term electrets was calibrated by DJS using a lower activity NIST standard (4971-3) whose emanation was  $0.821 \text{ Bq d}^{-1}$ . The Calculated to Measured ratio was 1.00.

### **RADON FLUX USING LARGE ACCUMULATORS AND EICs**

In early experiments, a radon flux measurement system that used discrete components was tested. A 3L hemispherical metal bowl with an opening of  $0.04 \text{ m}^2$  ( $0.43 \text{ ft}^2$ ) was attached to the surface and sealed with adhesive clay around the edge. On some rough and dirty vertical surfaces, it was necessary to add a quick fixing adhesive to the rim in addition to the clay seal to insure mechanical stability and low radon leakage. A standard EIC was enclosed in the bowl. At the end of desired period, typically 8 to 24 hours, the bowl is removed from the surface and the EIC electret measured similar to the standard procedure with any electret ion chamber. Then equation (1) is used to calculate the flux. Long-term electrets were used when the radon emanation was expected to be high. Figure 2 shows two of these systems and an RFM on a vertical granite surface.



Fig 2 Two discrete component flux monitors and one RFM deployed on a vertical granite surface.

### **RADON FLUX USING LARGE ACCUMULATORS AND CRMs**

Another discrete component radon flux system consisted of an inverted 4.6 L metallic bowl with a small continuous radon monitor (CRM) inside. Edges were sealed with adhesive clay. At the end of the accumulation period, the bowl removed and the hourly data down loaded. Equation (4) (Kotrappa, 2009) is used for calculating the radon flux from the data obtained from hourly readings of a continuous radon monitor

$$C(Rn) = \frac{(F \times A)}{V \times k} (1 - e^{-k \times T}) \quad \text{---- (4)}$$

*Notation:*

*F* is the radon flux in Bq m<sup>-2</sup> d<sup>-1</sup>

*A* is the area of opening of the accumulator in m<sup>2</sup>

*k* is the effective decay constant of radon. This is 0.1814 d<sup>-1</sup> if there is no loss from leaks through seals or the granite itself.

*C(Rn)* is the radon concentration at any accumulation time of *T* in Bq m<sup>-3</sup>

*T* is the accumulation time in days

*V* is the air volume of the accumulator in m<sup>3</sup>

The radon flux *F* is calculated using equation (1) leads to a flux in units of Bq m<sup>-2</sup> d<sup>-1</sup>.

Flux in other units can be obtained by multiplying the result by; 0.0116 to convert to mBq m<sup>-2</sup> s<sup>-1</sup>, 0.105 to convert to pCi ft<sup>-2</sup> h<sup>-1</sup>, and 1.125 to convert to pCi m<sup>-2</sup> h<sup>-1</sup>.

Alternatively, the in growth equation (4) can be fit to determine *F*. In fact, if there are few leaks, a linear approximation can easily be fit to the in growth of the early hours (say 3 to 20 hours) to give a good estimate for *F*.

## RESULTS

### RADON FLUX MONITOR(RFM)

The RFM was used to measure the flux from a granite sample repeatedly with exposure periods ranging from 4 to 24 hours. Table 2 and Figure 3 show that the flux calculated using equation (1) is quite reproducible with a variation of ~14%.

Table- 2 Radon Flux Monitor on F granite for different accumulation time

Rn pCi/L	Hours	Volume M3	A m2	FxA Bq/day	Flux
23.2	4	0.00095	0.01887	9.8647	523
49.3	8	0.00095	0.01887	10.6158	563
55.0	12.5	0.00095	0.01887	7.6557	406
73.7	16	0.00095	0.01887	8.0869	429
114.8	20	0.00095	0.01887	10.1819	540
101.3	24	0.00095	0.01887	8.9775	476

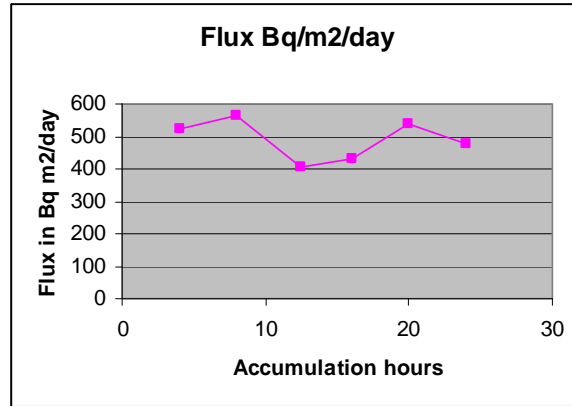

Fig 3 Calculated Radon Flux at stated accumulation time

**RADON FLUX USING LARGE ACCUMULATORS AND CRMs**

Figure 4 shows the results of calculating the radon flux using equation (4) at each hour after the exposure started. While the variation of the calculated flux during each hour during the entire experiment was 11%, it would only be 6% if the average flux result during the last 10 hours was used.

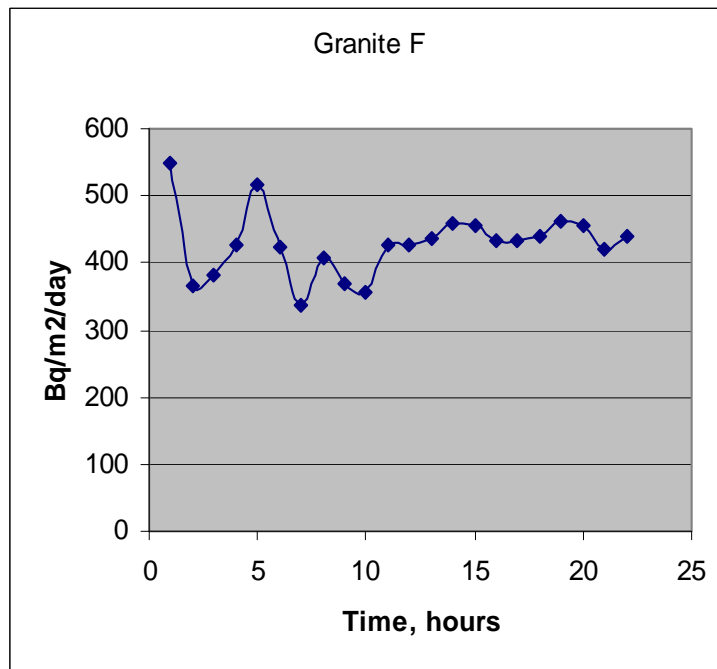

Fig 4 Calculated Radon Flux at stated accumulation time

**COMPARATIVE PERFORMANCE OF RADON FLUX SYSTEMS**

Six different granite samples were repeatedly measured on both sides with a variety of radon flux measurement systems. In addition to the 3 flux measuring systems described



above, an enclosure-style system was used to get the radon emanation from all surfaces of a granite sample. That system consisted of a 24 L metal enclosure in which a granite sample and a continuous radon monitor could be sealed. Figure 5 shows this system.



Fig 5 Enclosure accumulator with CRM and granite sample

In this CRM based systems, the flux was determined by fitting the in growth curve using an appropriate function (equation 3) reflecting the actual radon loss rate ( $k$ ).

Figure 6 shows an experiment with bowl accumulators applied to the “non-polished sides” of the samples. Five of the granite samples had quite high radon emanation that varied significantly across the surface. Since the RFM “ footprint” would cover only 20% of a top or bottom surface, while the bowl accumulators covered roughly 40%, it is not surprising that there is some variation in flux measured by the different systems.

Table 2 shows the comparative performance of the different systems on the six granite samples.

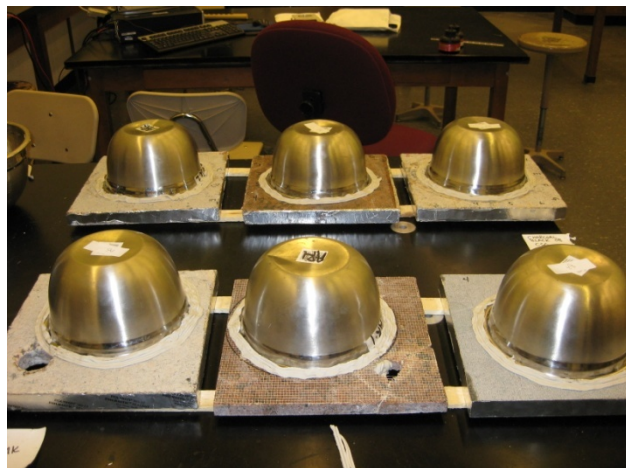

Fig 6 Accumulators applied to the “non-polished” sides of six granite samples

Table 3 Radon fluxes in pCi ft<sup>-2</sup> h<sup>-1</sup> for different granite samples measured with 4 different systems.

Method	Enclosure +CRM	5L Bowl +CRM	3L Bowl +EIC	RFM
<b>Sample/surface</b>				
<b>CK08</b>				
polished		16	11	18
rough		13	21	21
all surfaces	16	15	16	20
<b>CB08</b>				
polished		100	90	70
rough		260	250	270
all surfaces	155	180	170	170
<b>FS08</b>				
polished		30	30	25
rough		450	510	525
all surfaces	310	240	270	275
<b>FSMK</b>				
polished		42	46	52
rough		215	230	370
all surfaces	160	129	138	211
<b>JB08</b>				
polished		120	105	160
net		1	10	8
all surfaces	80	61	58	84
<b>JBMK</b>				
polished		495	430	829
net		365	290	280
all surfaces	415	430	360	555

The grayed numbers are averages of the two results above for comparison to the flux in the first column. Sample CK08 has flux typical of many granites and is quite spatially homogeneous. The other samples show variation in gamma activity across their surfaces which suggests that the emanation too may be inhomogeneous across their surfaces. While the 3L and 5L bowls cover about 0.45 ft<sup>2</sup>, the RFM only covers about 0.2 ft<sup>2</sup>. Samples FS08 and FSMK are from the same slab. Samples JB08 and JBMK are from granite with the same name but are from different slabs. JBMK has a small “hot spot” at the center of the polished side that covers about half of the RFM opening and about 20% of the opening for the bowl accumulator systems.

## **SENSITIVITY AND RANGE**

The standard procedure of calculating sensitivity and range, applicable to other electret ion chambers is also applicable to the EIC in this radon flux monitor (Kotrappa, 1990). A 20 volt drop is considered as the detectable limit for 10% accuracy. A 500 volt drop is considered as the range. It is found that a 50 volt drop in 8 hours leads to  $267 \text{ Bq m}^{-2} \text{ d}^{-1}$ . Using this as the basis, the table of sensitivity and range is calculated.

This means about  $107 \text{ Bq m}^{-2} \text{ d}^{-1}$  can be measured with 10% accuracy in an 8 hour. The ST electret in the EIC goes out of range for more than  $2670 \text{ Bq m}^{-2} \text{ d}^{-1}$  in an 8 hour measurement. In such cases a LT electret (Kotrappa, 1990) with a lower sensitivity by a factor of 12.5, is used.

Following Table gives the sensitivity and range for different electrets for 8 hour measurement.

Table-4 Sensitivity and Range

<b>Electret Type</b>	<b>Sensitivity (<math>\text{Bq m}^{-2} \text{ d}^{-1}</math>)</b>	<b>Range (<math>\text{Bq m}^{-2} \text{ d}^{-1}</math>)</b>
ST (short term)	120	3003
LT (Long term)	1504	37547

## **DISCUSSION OF RESULTS**

Table-1 gives the calibration data with a NIST radon emanation standard. Three sets of data show that the results are highly reproducible. The ratio of theoretical results is about 10% higher than the measured results. This may be taken as the calibration correction. This difference may be due to uncertainties in EIC calibration and in the measured dimensions of radon flux monitor. Additional calibration work done by DJS with NIST sources showed good agreement for the ST system and reasonable agreement for the LT system as discussed above.

Table-2 and Fig 3 gives results on measurement done on Granite sample F. This granite sample is obtained from a local granite manufacturer. The dimensions of the sample are 12 inch long, 12 inch wide and a thickness of 1.25 inches. All measurements are done on a polished side. The unpolished side has a resin with fiber glass mesh. This is one of the typical types sold. The radon flux is in the range of  $400$  to  $550 \text{ Bq m}^{-2} \text{ d}^{-1}$ . The results do not appear to vary systematically with the accumulation time. An 8 hour measurement is recommended for routine measurement.

Figure 4 give results of another independent measurement done on the same slab with large inverted bowl and a continuous radon monitor. There are wide fluctuations in results in the range of 1 to 8 hours. This is largely due to low sensitivity of the CRM at these periods. However after 8 hours, the calculated flux appears to stay stable. The

results appear to agree fairly well with the results obtained with radon flux monitor (Table-2). Agreements prove that both methods are acceptable for field use.

Table-4 is generated by the author (DJS) on large number of samples using different accumulators and different types of radon monitors. The radon flux monitor results, shown in the far right column generally agree with the other devices. Some differences in the results can be due to the non uniformity of radon flux on surfaces along with the differences in the accumulators' foot prints.

## **CONCLUSIONS**

The light weight radon flux monitor is simple to use and provides results similar to the other advanced accumulator based flux methods. The measurements for this radon flux monitor, and others, were validated using NIST radon emanations standards.

## **REFERENCES**

- Kitto ME, Green J Emanation from granite countertops. Proceedings of the American Association of Radon Scientists and Technologists 2005 International Symposium, San Diego CA ( 2005)
- Kitto M.E, Haines D.K, Aruzo H.D. Emanation of radon from household granite, Health Physics: 6:477-482 (2009)
- Kotrappa P, Dempsey J.C, Ramsey R.W and Stieff L.R. A practical E-PERM® System for indoor radon measurement, Health Physics 461-467 (1990)
- Kotrappa P, Stieff LR, Volkovitsky P. Radon monitor calibration using NIST radon emanation standards: steady flow method. Radiation Protection Dosimetry 113:70-74:2005
- Kotrappa P and F Stieff. . Radon exhalation rates from building materials using electret ion chamber in accumulators. Health Physics 97:163-166 (2009)
- Steck DJ. Pre- and post-market measurements of gamma radiation and radon emanation from a large sample of decorative granites, Proceedings of the American Association of Radon Scientists and Technologists 2009 International Symposium St. Louis MO.(2009)
- Volkovitski P. NIST 222 Radon emission standards, Applied Radiation and Isotopes. 64:1249-1252; 2006